

Facilitator's Guide to Magnetism

Magnetism, along with gravity and electricity, is a universal force of nature. This force is prevalent in our everyday lives: Magnetism is a property of certain metals and is also generated by electric currents inside circuits and, on a much larger scale, within planetary interiors. Earth itself has a magnetic field, as does the Sun, Jupiter, and other planets and moons.

Magnets are familiar sources of magnetic fields. Bar magnets have two "poles"; similar poles repel and different poles attract.

Magnetic fields are invisible, but they can be detected by the interaction between the magnet and another magnet or a magnetic material. This familiar magnetic attraction and repulsion is how compasses work. A compass is made up of a magnet mounted such that it can swing freely and align itself with any nearby magnetic fields.

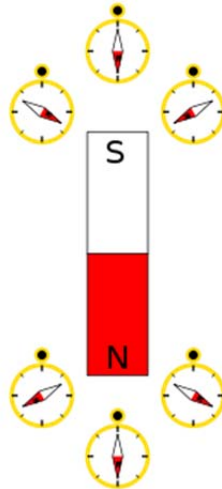

Bar magnets have a north and south pole. When a compass is brought near the magnet, the arrow aligns itself with the magnetic field and points toward the magnet's south pole. Credit: [Wikimedia Commons](#).

Planetary Magnetic Fields

A compass held steady in a location away from power lines and buildings will align itself with the Earth's magnetic field. Earth's magnetic field is similar to a bar magnet's: it has a north and south pole, and these poles happen to roughly line up with geographic north and south. Interestingly, the poles are flipped with respect to each other! The Earth's magnetic north pole lies near the geographic south pole, and vice versa. The compass' magnetic north pole is, by convention, the arrow, and this is attracted to the Earth's magnetic south pole. Thus, a compass arrow points roughly toward the geographic North Pole — it's askew by only 11°. It is a fluke of nature that

Earth's magnetic field happens to point more or less along Earth's axis. Planetary magnetic field can be oriented in any direction: the use of a compass for navigating on Uranus would get you lost, indeed, as its magnetic field is askew by 59°!

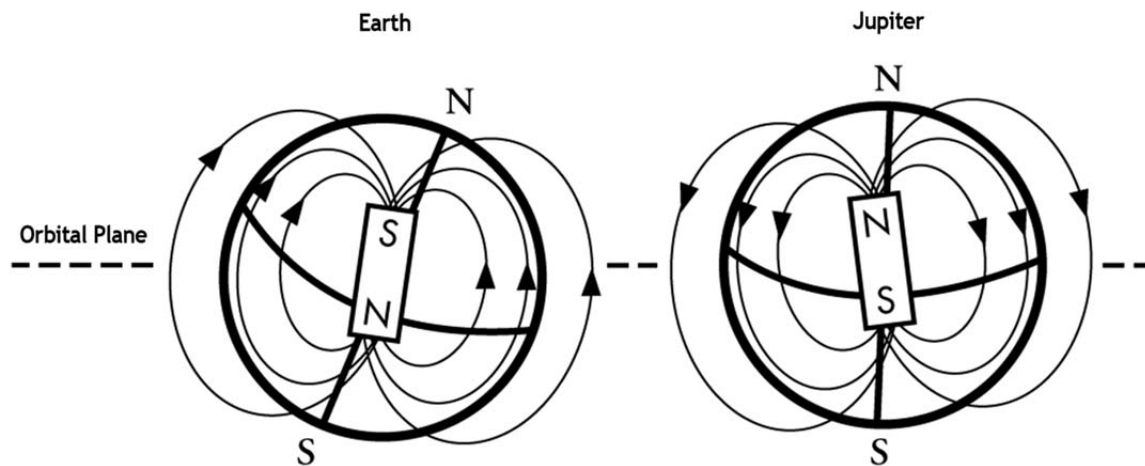

Planetary magnetic fields, like those of Earth and Jupiter, resemble those of bar magnets. Credit: Modified from [NASA](#).

Scientists are still investigating the planets' magnetic fields. Earth's is generated from flow within its liquid metallic outer core, and Jupiter's is thought to come from a very dense, fluid "metallic" layer of hydrogen compressed to act like a metal. Earth's and Jupiter's magnetic fields extend far out into space in three-dimensional shapes called magnetospheres. Jupiter's magnetic field is enormous — over 100 times Jupiter's diameter (Earth's field is 10 times Earth's diameter). Both Earth's and Jupiter's magnetic fields interact with the charged particles that the Sun is "blowing" outward — the solar wind. Jupiter's field also interacts with the moons that orbit Jupiter.

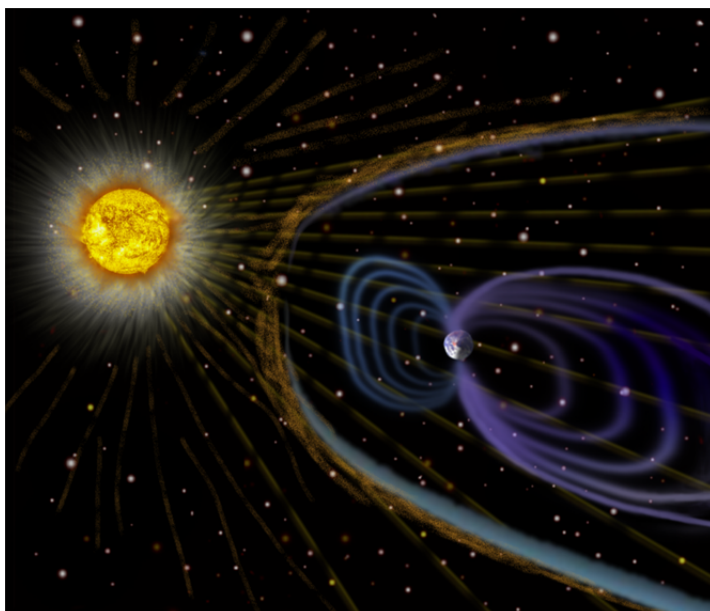

Charged particles from the solar wind are trapped by the Earth's magnetosphere, shown as arcs connecting the north and south poles, and can be slammed into the atmosphere to produce auroras.

Credit: Courtesy of SOHO consortium. SOHO is a project of international cooperation between ESA and NASA.

Jupiter is shrouded by its large magnetosphere in this artist's depiction of the planet's magnetic field lines stretching out into space. Jupiter's magnetosphere contains particles, marked with gold and silver, which produce auroras when they are slammed into the atmosphere. The particles are trapped from the solar wind and from Jupiter's volcanically active moon, Io.

Credit: [NASA/CXC/M.Weiss](#).

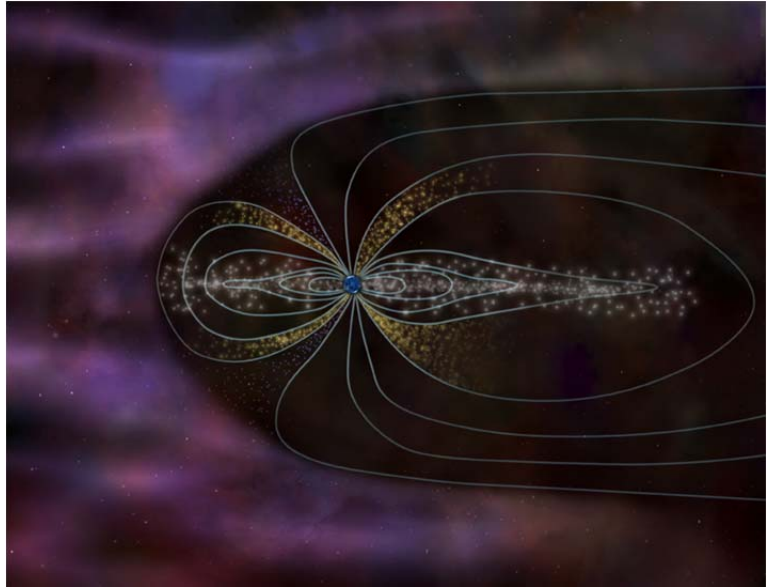

Planetary magnetic fields can be detected by compasses (and on spacecraft, by sophisticated instruments called “magnetometers”), and they are also evidenced by other, more spectacular displays. Particles from the solar wind, and in the case of Jupiter, spewed from its volcanic moon, Io, are accelerated along magnetic field lines. They produce radio signals that, when translated much in the same way as radio stations transform radio signals into sound, are melodious. When the particles slam into the atmosphere near the north or south poles of a planet, they produce the northern or southern lights — aurora. Radio signals and aurora are characteristic signatures of the magnetic fields of Earth and Jupiter.

Deeper Investigations

The following suites of classroom activities offer excellent introductions to magnetism:

- [Exploring Magnetism](#), The Center for Science Education at the Space Sciences Laboratory, University of California at Berkeley.
- [Mapping Magnetic Influence: An Educator's Guide with Activities in Physical Science](#), NASA educational product number EG-2005-2-026-GSFC.