



**Aerospace
Systems Division**

A2 ALSEP Data Transmitter
Reliability Prediction

NO. ATM-856	REV. NO. A
PAGE <u>1</u> OF <u>6</u>	
DATE 6-15-70	

Several modifications have been made to transmitter since the original release of this reliability prediction. This revision to ATM-856 updates that prediction to correspond the current transmitter circuit diagram depicted in Bendix drawing 2344610, Revision G (with ECN 2344610 G2).

The revisions to the transmitter circuit_ since the original release of the reliability prediction are documented in Bendix CRD's #57862 (to Rev. D), #57988 (to Rev. E), #58666 (to Rev. F), and #58679 (To Rev. G). These design changes were incorporated primarily to suppress conducted EMI and to improve the stability and tuning characteristics of the power amplifier in the transmitter.

The result of these circuit changes is a slight improvement in the overall transmitter reliability. For the transmitter, the new prediction is .98901 vs. 98889, based on the transmitter FMECA (ATM 854-Rev. A). In the standby redundant configuration this gives a new prediction of .99985.

Based on the Transmitter Parts Applications Analysis (ATM 841-Rev. B), the reliability prediction becomes 0.97492, up from 0.97410. This gives a stand-by redundant configuration prediction of .99932.

In summary, the modifications to Data Transmitter have not degraded the predicted reliability, and have in fact slightly improved the estimate.

Revised by:



T. W. Fox
ALSEP Reliability Dept.

Approved by:

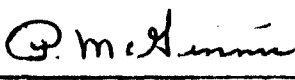

P. McGinnis
ALSEP Reliability

1.0 Scope

This report presents the Data Transmitter reliability prediction estimates derived through the studies of Data Transmitter Failure Mode, Effects and Criticality Analysis (FMECA) and Data Transmitter Parts Application Analysis (PAA).

2.0 Conclusion

The Data Transmitter has reliability of .98901 for a one year mission which more than meets the design goal of .985.

The stand-by redundancy of the Data Transmitters (2) effected through the diplexer switch has a reliability of .99985 which is indeed very close to unity.

3.0 Reliability Prediction Estimates

Figure 1 presents the Data Transmitter Reliability Block Diagram, and gives the prediction estimates for the Transmitter (.98901) and of its constituent subassemblies. Figure 2 presents the Data Transmitter Reliability Block Diagram in the standby redundant configuration, and gives the prediction estimate for this configuration as .99985.

The prediction estimates given in Figures 1 & 2 are derived through the Data Transmitter FMECA described in ATM 854 Rev. A and dated 15 June 1970. This study has utilized the reliability data of the Transmitter Parts Application Analysis (PAA) on a failure mode basis and not on a parts count basis.

Figure 3 presents the same Reliability Block Diagram of Figure 1, and gives the prediction estimates derived through Data Transmitter PAA, described in ATM 841B and dated 15 June 1970. Similarly, Figure 4 gives the Transmitter prediction estimate for the redundant configuration (.99932). The predictions derived through the PAA analysis are based on the Transmitter total parts count and the failure rates for each and every part.

Data Transmitter Reliability = .98901

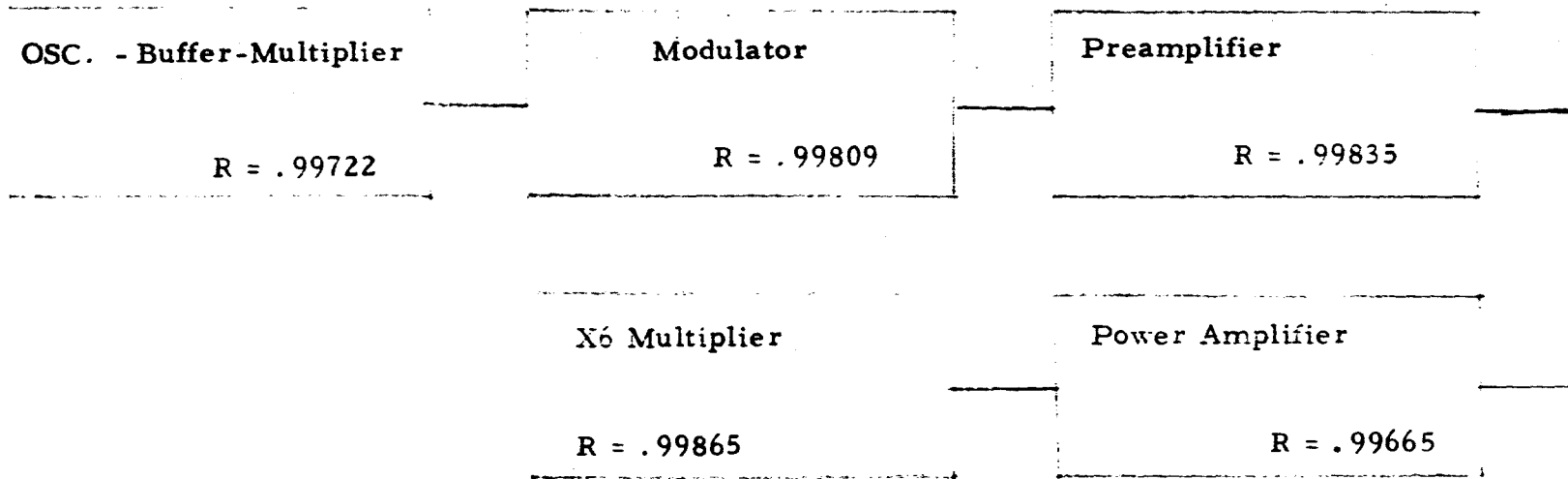
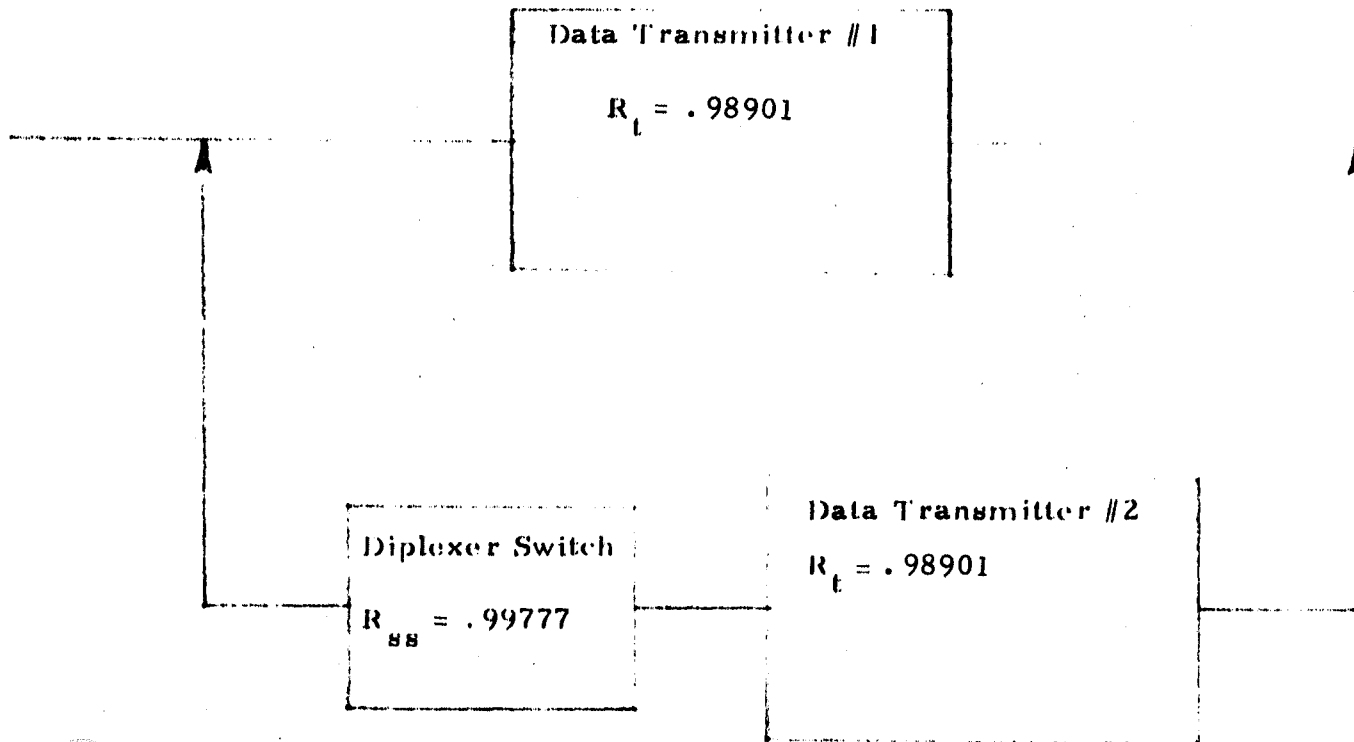

Figure 1. Data Transmitter Reliability Block Diagram.

Reliability Prediction per Failure Mode & Effects Analysis



Reliability of Redundant Transmitters: R

$$\begin{aligned}
 R &= R_t + R_{SS} R_t \times \lambda_t \tilde{t} \sim R_t + R_{SS} R_t (1 - R_t) \\
 &= .98901 + .99777 \times .98901 \times .01099 \\
 &= .99985
 \end{aligned}$$

Figure 2. Reliability Block Diagram of Redundant Transmitters.

Reliability Prediction per Failure Mode & Effects Analysis.

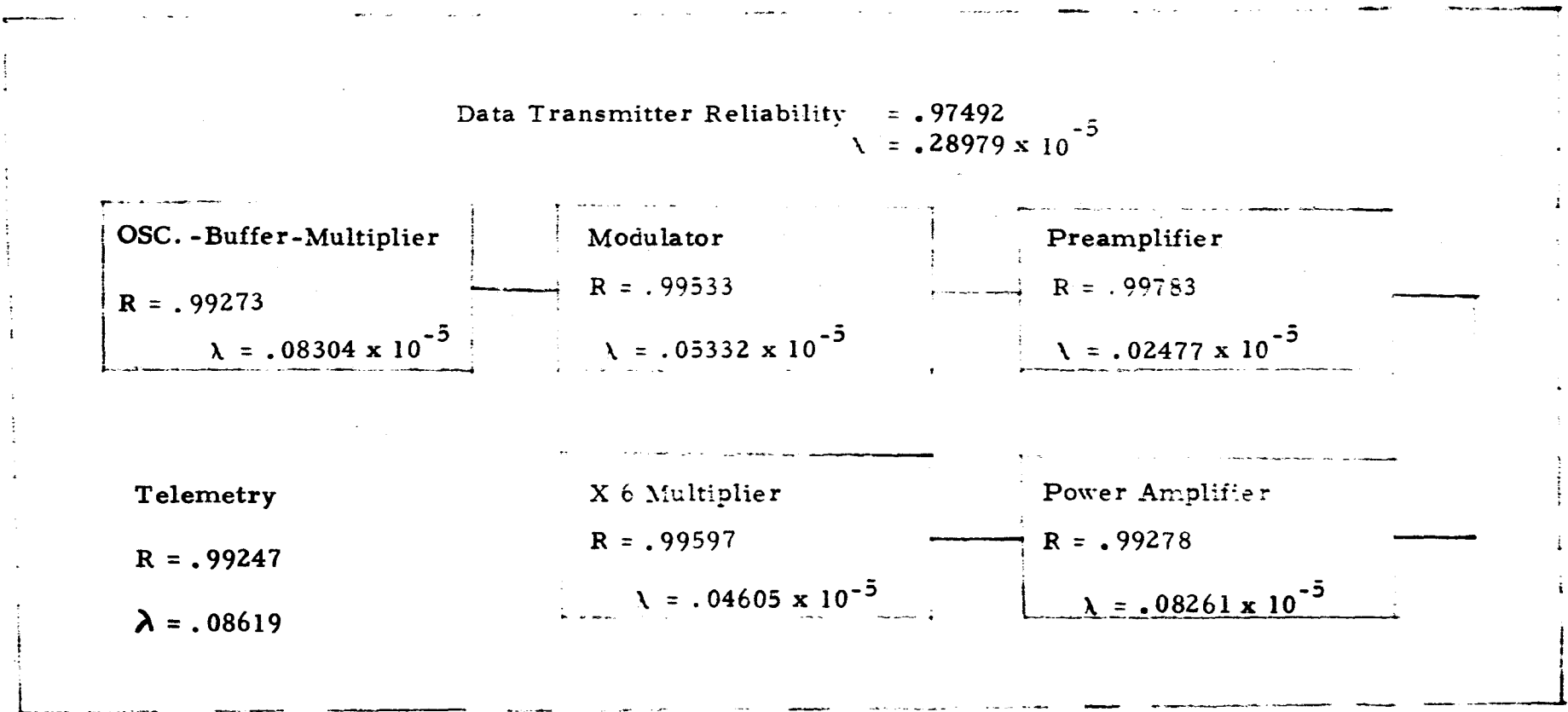
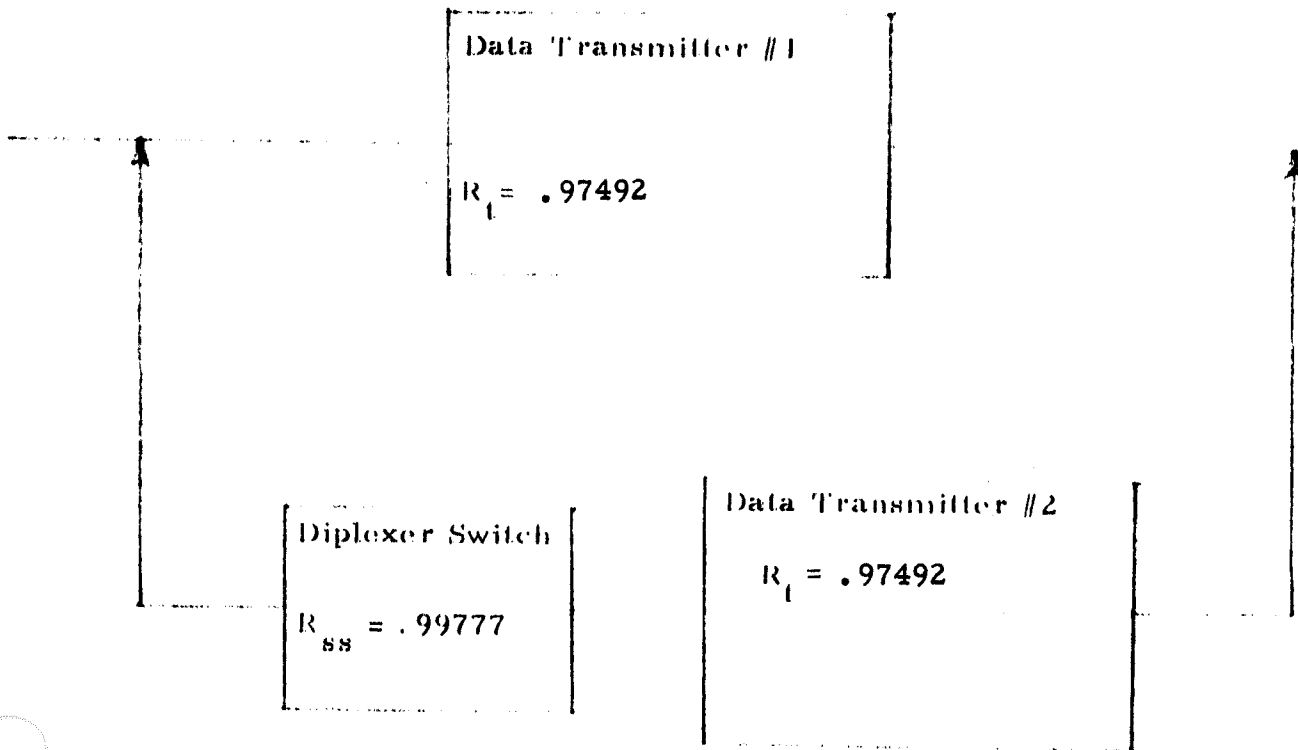

Figure 3.

Data Transmitter Reliability Block Diagram.

Reliability Prediction per MIL-STD-756A & PAA



Reliability of Redundant Transmitters: R

$$\begin{aligned}
 R &= R_t + R_{ss} R_t \times \lambda_t \sim R_t + R_{ss} R_t (1 - R_t) \\
 &= .97492 + .99777 \times .97492 \times .02508 \\
 &= .99932
 \end{aligned}$$

Figure 4. Reliability Block Diagram of Redundant Transmitters.

Reliability Prediction per MIL-STD-756A & PAA