



**Aerospace  
Systems Division**

Reliability Evaluation of  
Bulova Accutron Timers

NO.	REV. NO.
ATM 828	
PAGE <u>1</u>	OF <u>9</u>
DATE	4/22/69

The purpose of this ATM is to document the results of a special Reliability Evaluation Test performed by the Bendix Aerospace Systems Division on the ALSEP Central Station Timer to determine if previously identified timer indexing failure modes had been eliminated.

Two ALSEP Central Station Timers, PN 2330626 Revision F, were subjected to 36 simulated lunar temperature cycles in a vacuum over the range of  $-10^{\circ}\text{F}$  to  $+150^{\circ}\text{F}$ .

No anomalies were observed during the test. Post test examination of timer index wheels established the wheels were acceptable.

Prepared by: P. McGinnis  
P. McGinnis

Approved by: S. J. Ellison  
S. J. Ellison, Manager  
ALSEP Reliability

CONTENTS

- 1.0 Scope and Objective of the Test
  - 1.1 Scope
  - 1.2 Objective
- 2.0 Summary of Results and Conclusions
  - 2.1 Results
  - 2.2 Conclusions
- 3.0 Detailed Test Description
  - 3.1 Test Items
  - 3.2 Test Methods and Details
  - 3.3 Analysis of Results

1.0 Scope and Objective of the Test

1.1 Scope

The test documented in this report represents a special reliability evaluation test of two (2) Bulova Accutron Timers of the same type and configuration as used in the ALSEP flight equipments.

The test was designed to provide an assessment of possible indexing mechanism failure modes which might be induced as a result of the timers being exposed to a simulated thermal/vacuum environment of the lunar surface.

1.2 Objective

The basic purpose of the testing of the timers was to determine if the timers exhibited any significant tendency to develop indexing failure modes during lunar surface operation.

2.0 Summary of Results and Conclusions

2.1 Results

Two Bulova accutron timers of the same type and configuration as used in ALSEP flight hardware, were conditioned in a vacuum at a temperature of  $140 \pm 10^{\circ}\text{F}$  for a period of 24 hours, functionally tested at room ambient pressure and temperature; they were then functionally tested in a thermal/vacuum environment with 36 temperature cycles over the range of  $-10^{\circ}\text{F}$  to  $+150^{\circ}\text{F}$ .

No anomalies were observed during the test. The two (2) timer index wheels were removed from the timers and taken to the Kennedy Space Center (KSC) Malfunction Analysis Laboratory for a Scanning Electron Microscope (SEM) examination. Examination of the index wheels at a magnification of 610X revealed some wear of the index wheel teeth; however, the shape or outline of the teeth was good and the degree of wear was normal for the number of thermal cycles to which the timers were subjected.



Reliability Evaluation of Bulova Accutron Timers	NO. ATM 828	REV. NO.
	PAGE <u>4</u>	OF <u>9</u>
	DATE 4/22/69	

2.2 Conclusions

On the basis of the results of this test, it is concluded that the Bulova Accutron Timer Model TE-12 is acceptable for use as an ALSEP Central Station events timer and that the flight worthiness of the ALSEP equipment is not affected.

3.0 Detailed Test Description

3.1 Test Items

The two (2) timers subjected to test were standard Bulova Accutron Timers, Model TE-12, modified per BxA Drawing 2330626F as follows:

- a. Beryllium copper wheel replaced with Paliney 7 wheel to improve wear characteristics.
- b. Dow Corning FS 281 jewel lubricant replaced with Krytox 240 AC lubricant to reduce wear, tackiness and debris build-up.
- c. Neoprene seals replaced with Viton seals to eliminate a source of sulphur.
- d. Index wheel spoke or teeth lubricant eliminated to prevent tackiness.
- e. Index wheels inspected via scanning electron microscope prior to installation to minimize imperfections.
- f. Magnification increased from 40X to 216X for examination of index and pawl jewel alignment with index wheel teeth during assembly to reduce "chiseling effect."
- g. Index and pawl jewel pressure reduced from eight (8) tooth engagement to six (6) tooth engagement to reduce wear of index wheel teeth.

3.2 Test Methods and Details

The two Bulova Accutron Timers were conditioned in a thermal/vacuum environment for a period of 24 hours at a temperature of  $+140^{\circ}\text{F} \pm 10^{\circ}\text{F}$  and functionally tested at room ambient pressure and temperature in accordance with TP 2334631. The timers were then subjected to a thermal/vacuum functional test in accordance with the procedure as outlined in Appendix A.

The test circuitry was devised to test the timer functional parameters while in a thermal/vacuum environment. Figure 1 in Appendix A illustrates the basic test set-up for each timer. The complete test equipment consisted of the following:

1. Conrad Environmental Chamber
2. Conrad Recorder (2 ea)
3. DC-VTOM
4. DC Power Supply (1 - 15 VDC)
5. VOM
6. Wide Range Oscillator (1 - 6000K H<sub>2</sub>)
7. 6" Cross Vacuum Chamber
8. Titanium Vacuum Pump
9. Titanium Pump Control
10. Switching Box

The detail test procedure encompassed the test set up and step-by-step operating instructions. Measurement/acceptance criteria were defined for the functional parameters. The test was monitored and data recorded periodically throughout the 36 simulated lunar missions with Quality Control surveillance. The temperature profile conditions were programmed by the Conrad Chamber temperature control cam. The lunar temperature cycle employed is illustrated as follows:

Temperature Cycle Profile

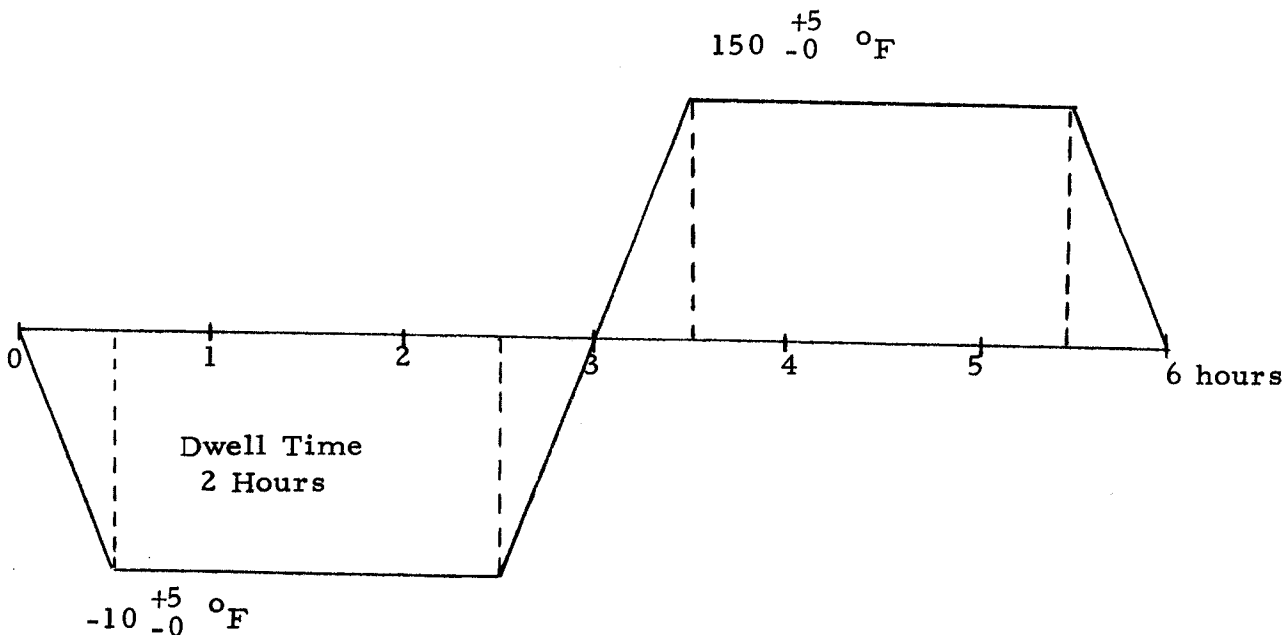



**Aerospace  
Systems Division**

Reliability Evaluation of  
Bulova Accutron Timers

NO.	REV. NO.
ATM 828	
PAGE <u>6</u>	OF <u>9</u>
DATE 4/22/69	

3.3 Analysis of Results

No anomalies were observed during the test. The timer index wheels were examined via a Scanning Electron Microscope (SEM) at the Kennedy Space Center (KSC) Malfunction Analysis Laboratory. Examination of the index wheels at a magnification of 610X revealed some wear of the index wheel teeth; however, the shape or outline of the teeth on each wheel was good and the degree of wear was normal for the test conditions.

APPENDIX A

ALSEP Central Station Timer Reliability Evaluation Test Procedure

The ALSEP Central Station Timer shall be subjected to a thermal/vacuum environmental test in accordance with the following procedure:

A. Test Department

1. Install the two timers in vacuum chamber.
2. Wire circuitry for each timer as shown in figure 1.
3. Close switch S<sub>4</sub>.
4. Start timer as follows:
  - a. Adjust 360 Hertz Sine gen. output to 0.5 v RMS.
  - b. Close switch S<sub>1</sub>.
  - c. Close switch S<sub>2</sub>.
  - d. Open switch S<sub>1</sub>.
  - e. Verify timer operation in "Start mode" by observing timer current & 1 minute switch closures.  
(S<sub>3</sub> closed)
  - f. Record timer current (12 u amp max. in "Start mode").
  - g. Open switch S<sub>4</sub>.
  - h. Verify timer operation in "Stop mode" by observing timer current.
  - i. Record timer current (7 u amp max in "Stop mode").
5. Record battery voltage (1.2 to 1.5 VDC).
6. Evacuate chamber to 10<sup>-5</sup> Torr or better.
7. Stabilize timer temperature at 50°F.
8. Switch timer to "Start mode" by closing switch S<sub>4</sub>.
9. Verify that the timer is in the "Start mode" by observing timer current (12 u amp max. ) and 1 minute switch closures.
10. Cool timer to -10°F and maintain at -10°F for a period of 2 hours. (Temperature shall not go below -10°F)
11. Raise chamber temperature to +150°F (min. )
12. Maintain chamber at +150°F (min. ) for a period of 2 1/2 hours.
13. Repeat steps 10 through 12 for a minimum of 36 complete thermal cycles.
14. Return chamber to room temperature.



**Aerospace  
Systems Division**

Reliability Evaluation of Bulova Accutron Timers		NO.	REV. NO.
		ATM 828	
		PAGE <u>8</u>	OF <u>9</u>
		DATE	4/22/69

B. Reliability & Q. A. Departments

1. Monitor temperature, pressure, 1 minute contacts, timer battery voltage and timer current periodically throughout test.



VACUUM

AMBIENT

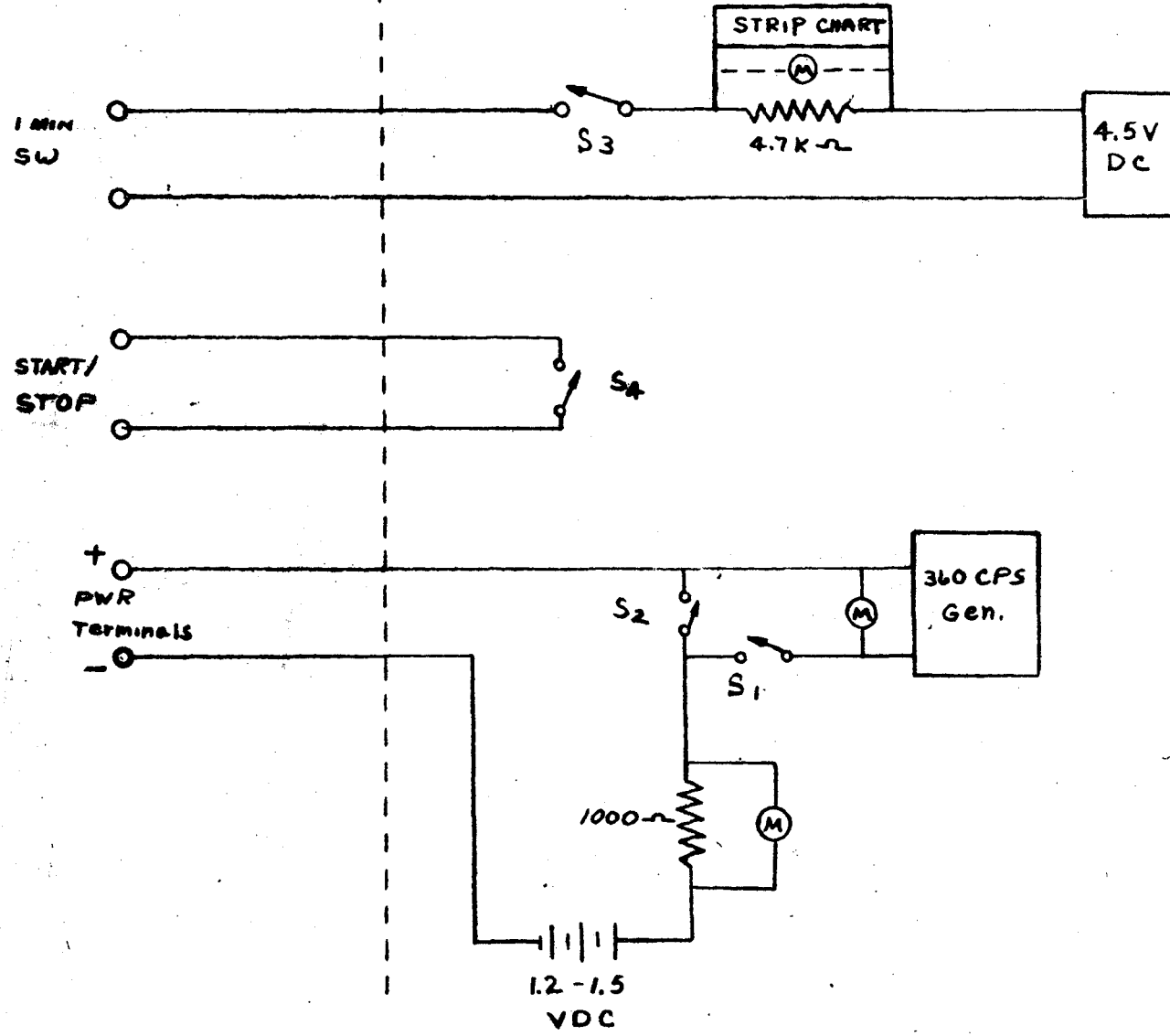

FIGURE 1